

# Stanilite®

## Platinum flood light LED weatherproof Nexus®

**p-Range**



Image indicative only

### Range

Platinum range

### Product group

Flood light LED



### Features

- 5 year warranty
- LED technology 100,000 hours plus lamp life
- Low power consumption and LED light source for reduced operation and maintenance costs
- Weatherproof rating IP65
- Advance charging technology combined with Lithium iron phosphate battery for long life and low maintenance
- Nexus monitored, either cabled or wireless
- Light output typically 600 lumens per lamp head
- Beam angle 120° flood
- Lamp heads can be rotated and tilted to suit particular installation requirements
- Easy to maintain and low maintenance cost
- Wall mounting
- UV stabilised enclosure
- Not suitable for installations where exposure to direct sunlight may occur
- Ambient operating temperature; WPFLxx210LEDP 10°C to 40°C, WPFLxx210LEDP-RMT remote lamp head -30°C to 40°C and WPFLxx210LEDP-RMT remote control gear 10°C to 40°C

Catalogue no.	Description
<b>Nexus products</b>	
WPFLX210LEDP	Platinum flood light LED weatherproof Nexus LX 2x10W non-maintained
WPFLX210LEDP-RMT *	Platinum flood light LED weatherproof Nexus LX 2x10W non-maintained with remote lamp head
WPFLRF210LEDP	Platinum flood light LED weatherproof Nexus RF 2x10W non-maintained
WPFLRF210LEDP-RMT *	Platinum flood light LED weatherproof Nexus RF 2x10W non-maintained with remote lamp head
<b>Spare parts</b>	
03-01316PB	Battery LiFePO4 12.8V 6.0Ah
15-10027	Lamp LED 10W

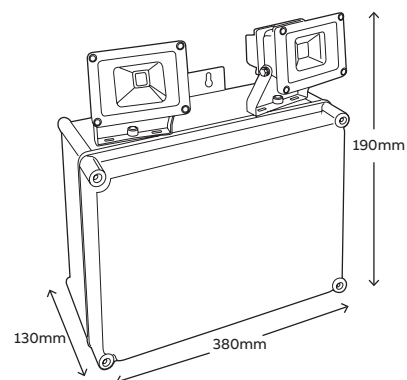

Dimensions		
Length	Width	Height
380mm	130mm	190mm
Weight		
Model	Weight	
Nexus LX/RF	4.0kg	
Construction		
Part	Construction	
Body and cover	Polycarbonate	
Lamp head	Diecast aluminium and steel bracket, white powder coated. Glass lens	
Light source		
Model	Light source	
Nexus LX/RF	LED 10W	
Power consumption		
Model	Power consumption	
Nexus LX/RF	42mA average / 130mA maximum	

## Photometrics

The photometric data below is calculated for a LED weatherproof flood light mounted at 3 metres, 4 metres and 5 metres. The lamp head must be positioned and aimed as shown in the drawings below.

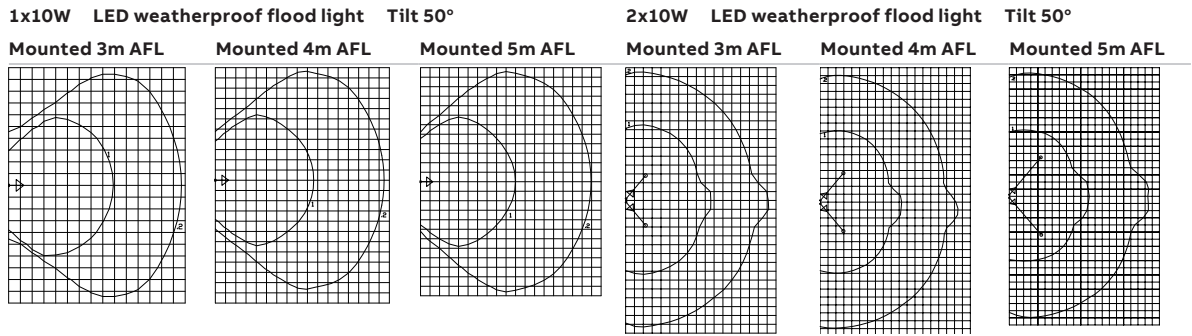

### Area coverage 0.2 lux min

200m <sup>2</sup>	265m <sup>2</sup>	320m <sup>2</sup>	340m <sup>2</sup>	420m <sup>2</sup>	500m <sup>2</sup>
-------------------	-------------------	-------------------	-------------------	-------------------	-------------------

### Area coverage 1.0 lux min

85m <sup>2</sup>	95m <sup>2</sup>	105m <sup>2</sup>	123m <sup>2</sup>	143m <sup>2</sup>	160m <sup>2</sup>
------------------	------------------	-------------------	-------------------	-------------------	-------------------

Note:

- The outer line represents 0.2 lux and inner line 1.0 lux
- Gridlines are 1 metre spacing
- AFL = Above Floor Level

Note:

- Designed to comply with AS2293 and meet relevant Australian EMC standards
- \* In accordance with AS2293, the maximum distance the control gear and battery can be located from the lamp source is 2m, if lamp source is beyond the 2m, depending on the site installation, protection against exposure to fire by the use of a fire-protected wiring may be required. Following below is a list indicating the maximum distance and cable size if the lamp source is 5, 10, 20 and 30m away from the control pack and batteries.

Distance	Cable size (per lamp head)
5m	1.0mm <sup>2</sup>
10m	1.5mm <sup>2</sup>
20m	2.5mm <sup>2</sup>
30m	4.0mm <sup>2</sup>